

# Build on the Built

Athens, 21<sup>st</sup> of October 2024

**Revealing the Qualities of a Site & Activating its Potential**



**Herzog & de Meuron**





Who we are





Where we are



Where we work



176 RÉFECTOIRE



178 PRADA



158 KRAMLICH



153 AARAU KUNSTHAUS



349 PARRISH



180 ELSÄSSERTOR II



166 COTTBUS



169 SHCAULAGER



160 LABAN DANCE CENTER



126 TATE MODERN

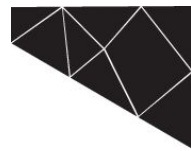

230 ELBPILHARMONIE



175 WALKER ART CENTER



164 CENTRAL CULTURAL



168 & 174 HELVETIA PATRIA



173 DE YOUNG MUSEUM



165 REHAB



190 FORUM 2004

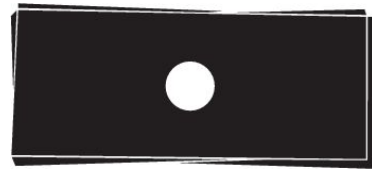

213 MESSE BASEL



377 KINDERSPITAL ZÜRICH

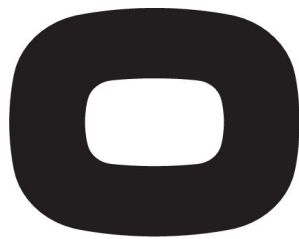

205 ALLIANZ ARENA

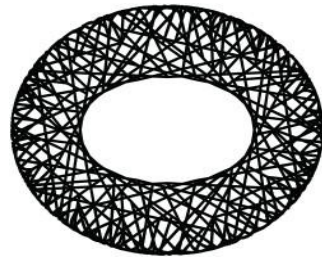

226 NATIONAL STADIUM



384 OBERES KANDERGRIEN

What we do



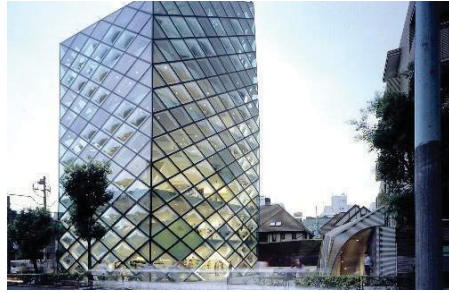

What we do





Dialogue



Workshop



Digital Technologies



Iterations



Mock-ups



How we work - Process



On Site

# How we work







# **126 Tate Modern**

London, UK

Project: 1995-1997, Realization: 1998-2000



126 Tate Modern, London, UK





126 Tate Modern, London, UK









126 Tate Modern, London, UK

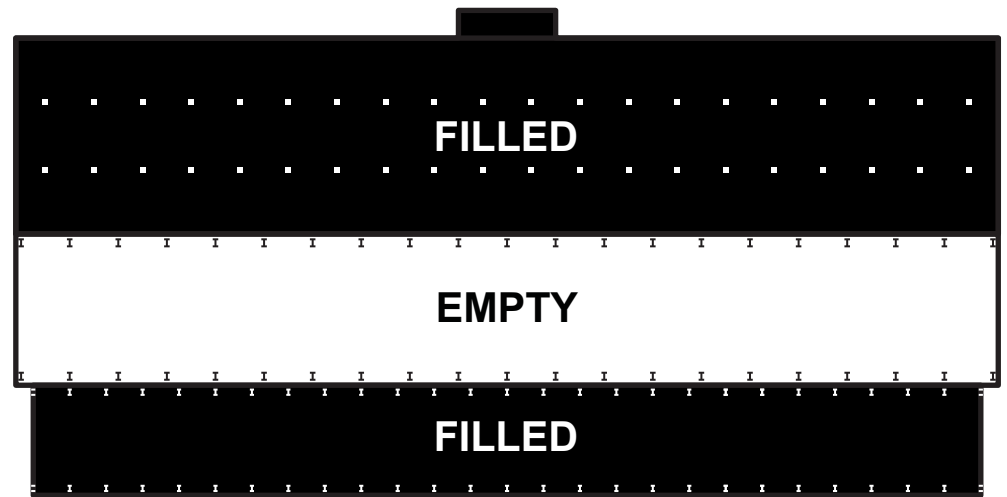
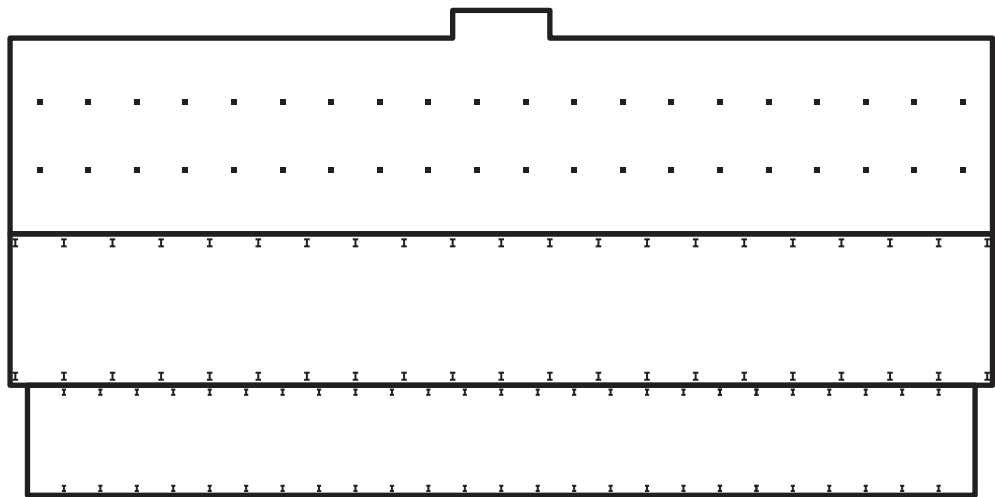

126 Tate Modern, London, UK



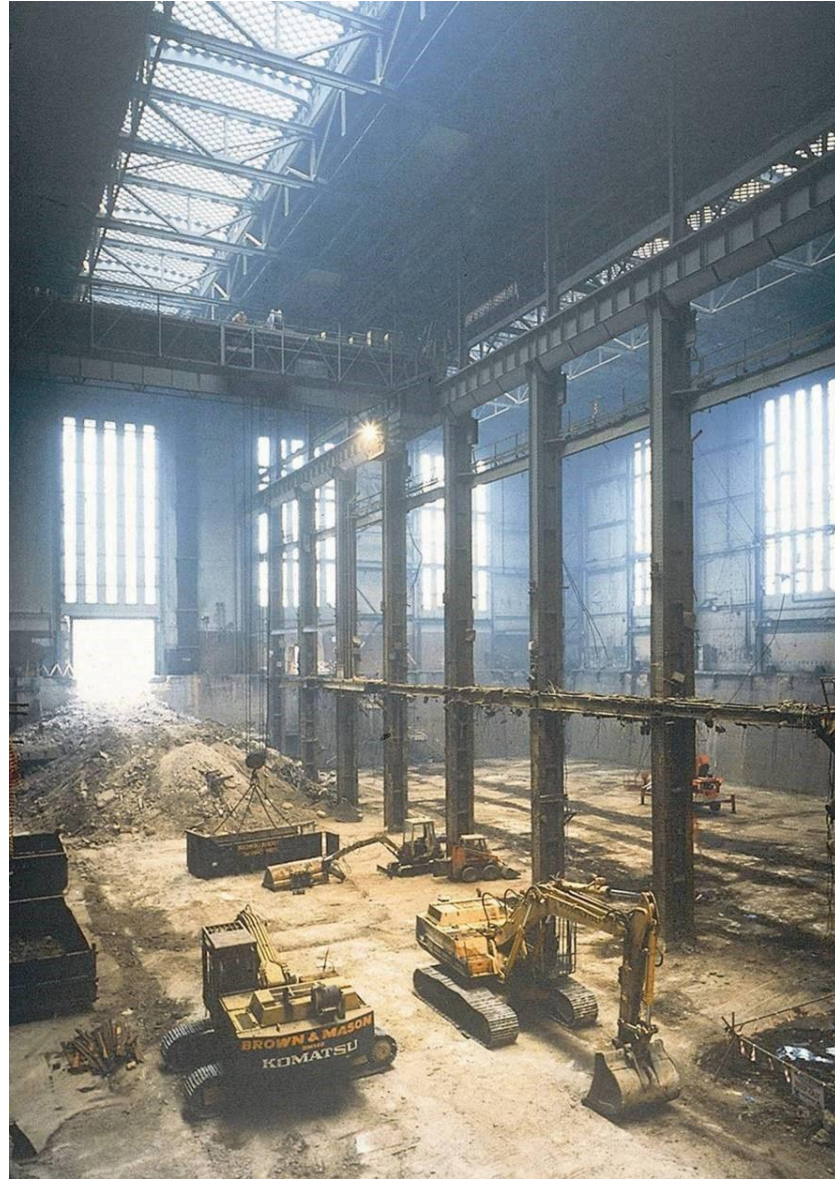

126 Tate Modern, London, UK







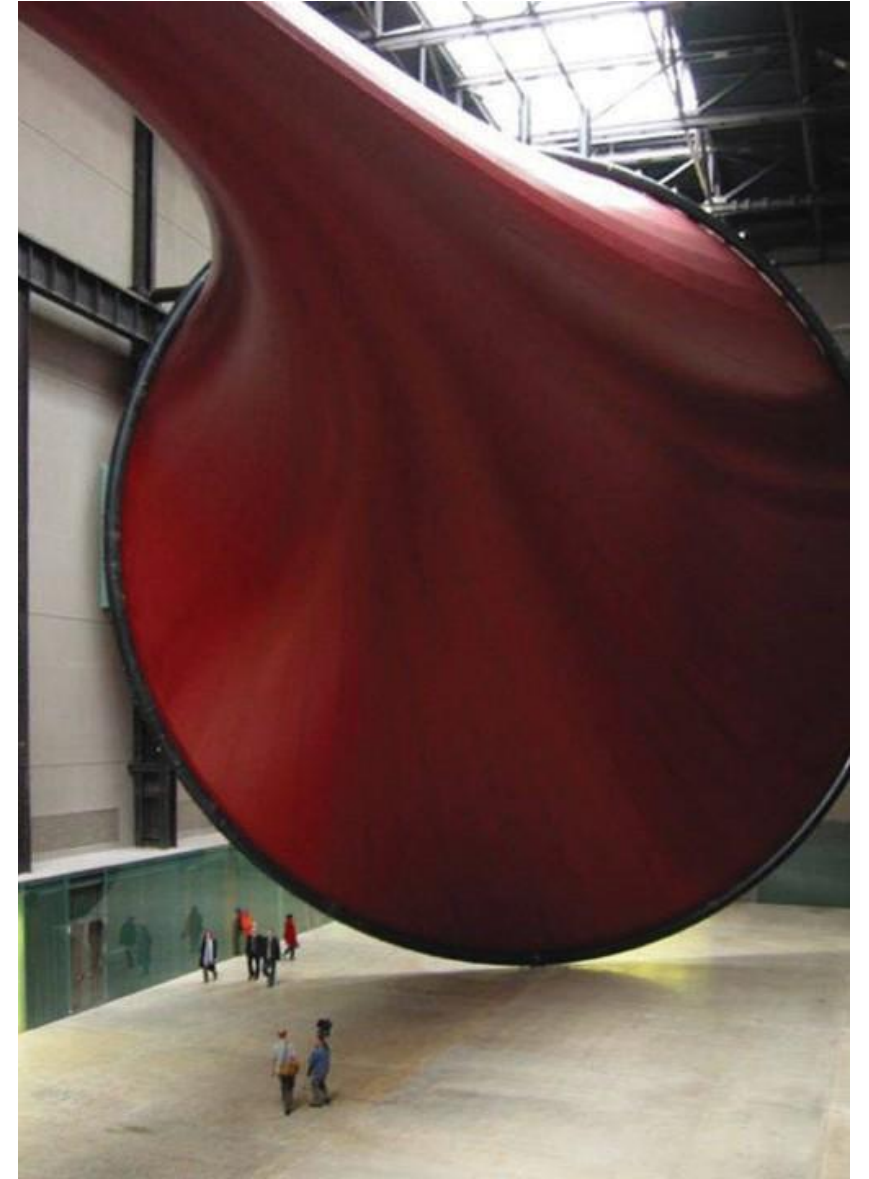

126 Tate Modern, London, UK



# **461 Powerhouse Arts**

Brooklyn, New York, New York, USA  
Project: 2016-2023



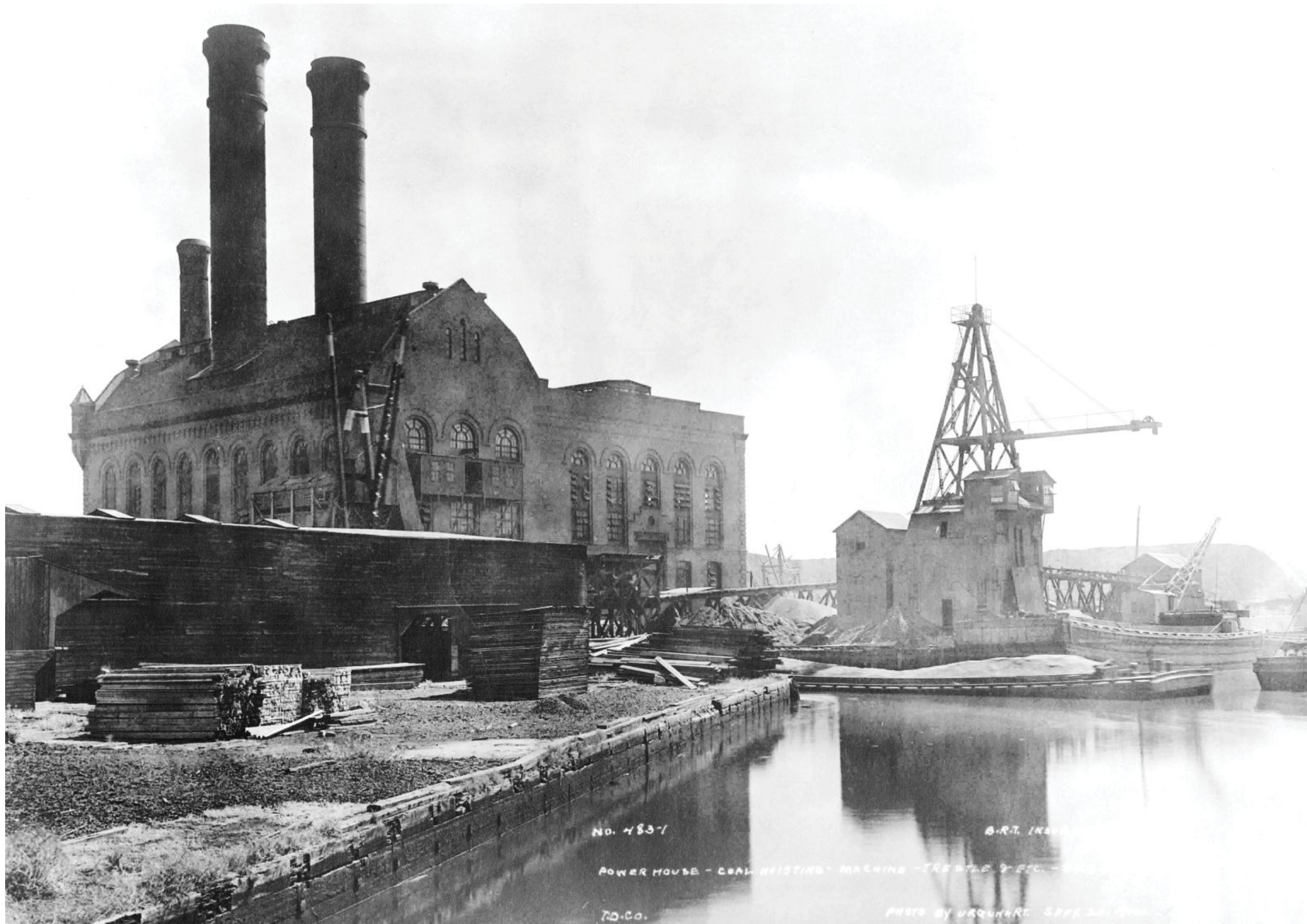

NO. 4837

B.R.T. INDIAN

POWER HOUSE - COAL HOISTING - MACHINE - TRUSS - ETC. - 1880

P.D.CO.

PHOTO BY URQUHART SPRINGFIELD

461 Powerhouse  
Arts



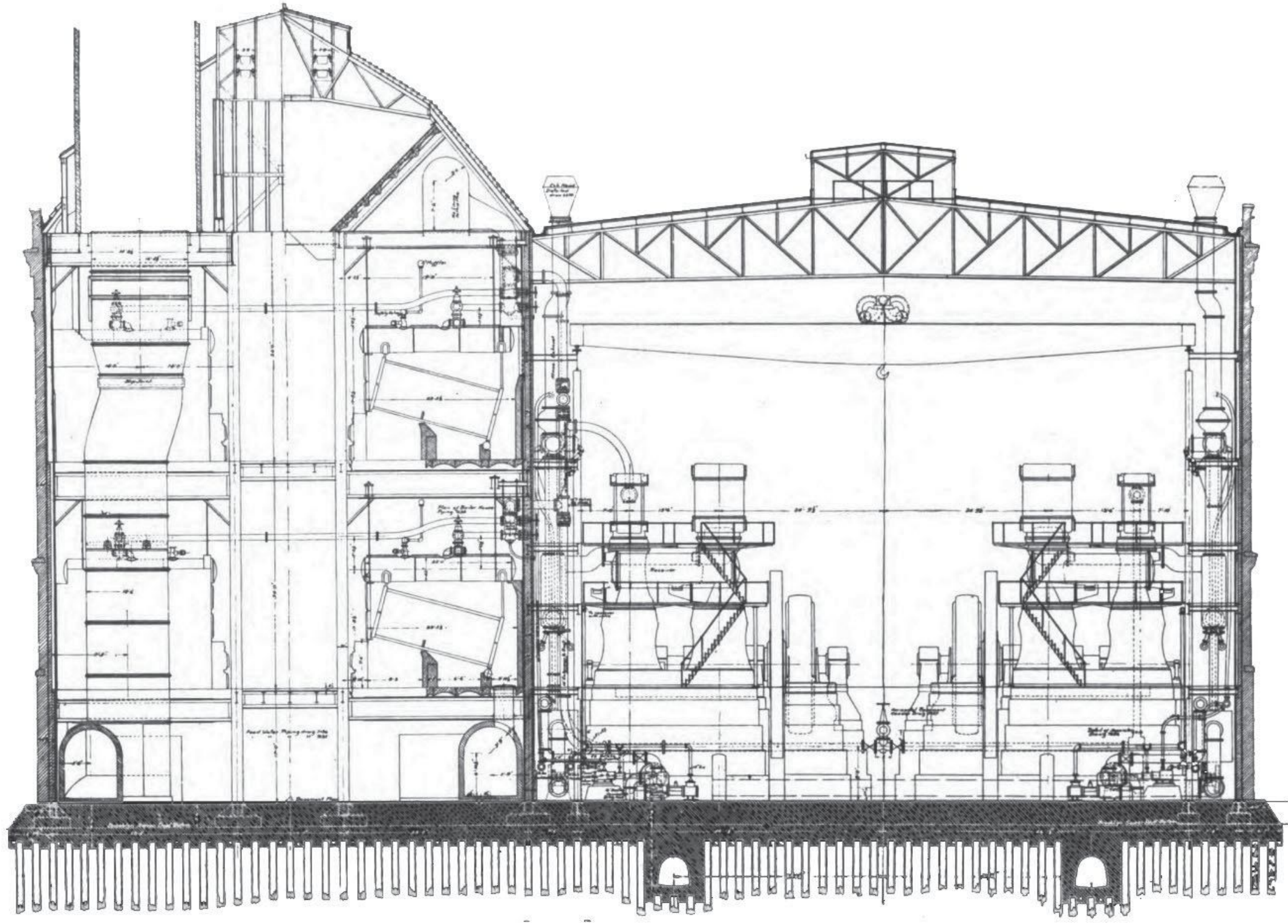

461 Powerhouse  
Arts





461 Powerhouse  
Arts



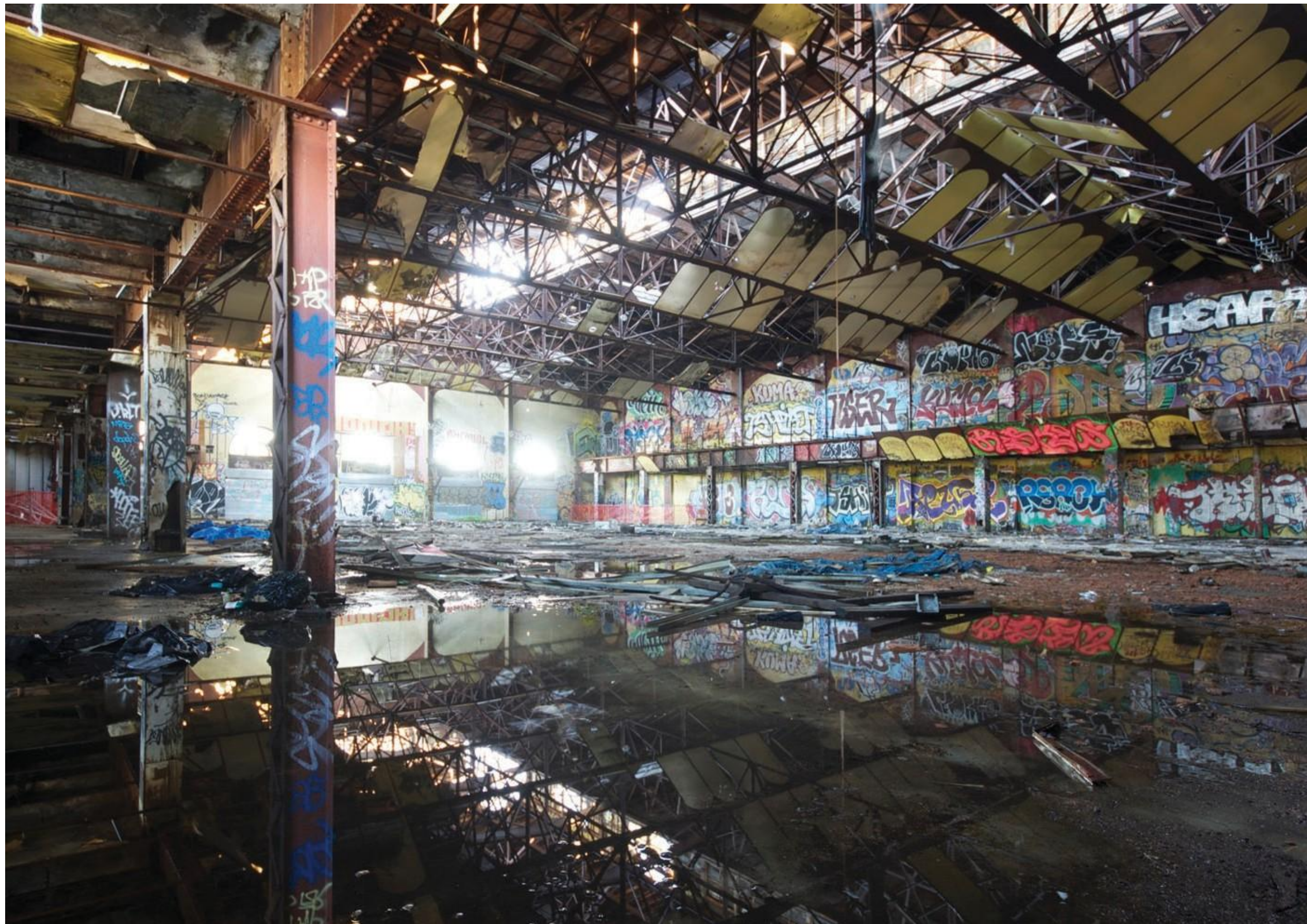

461 Powerhouse  
Arts



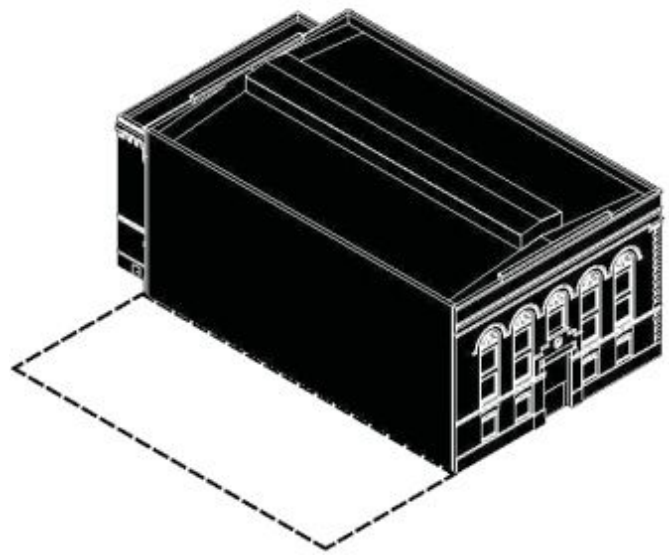

**EXISTING**

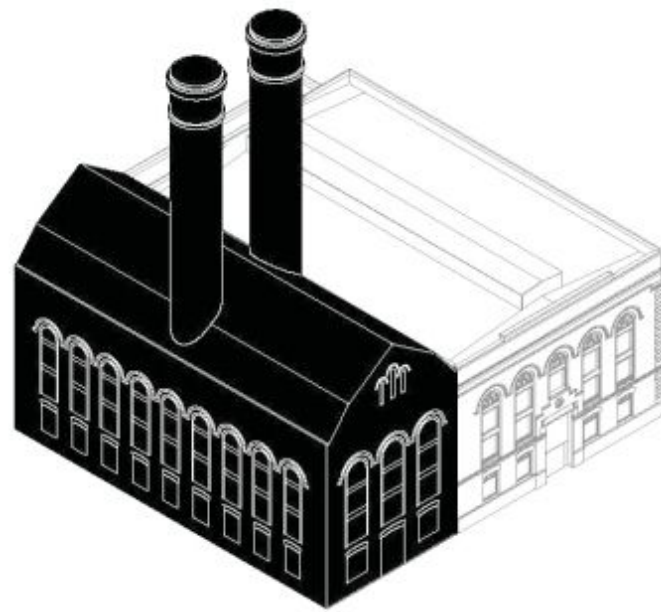

**RECONSTRUCTION**

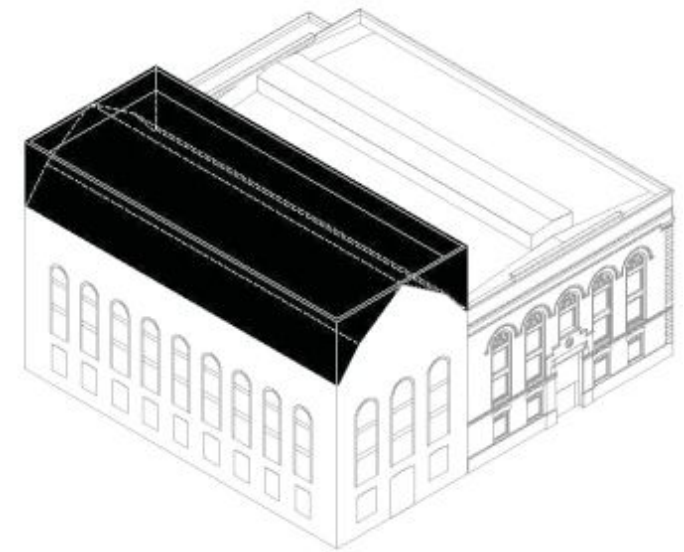

**ADDITION**



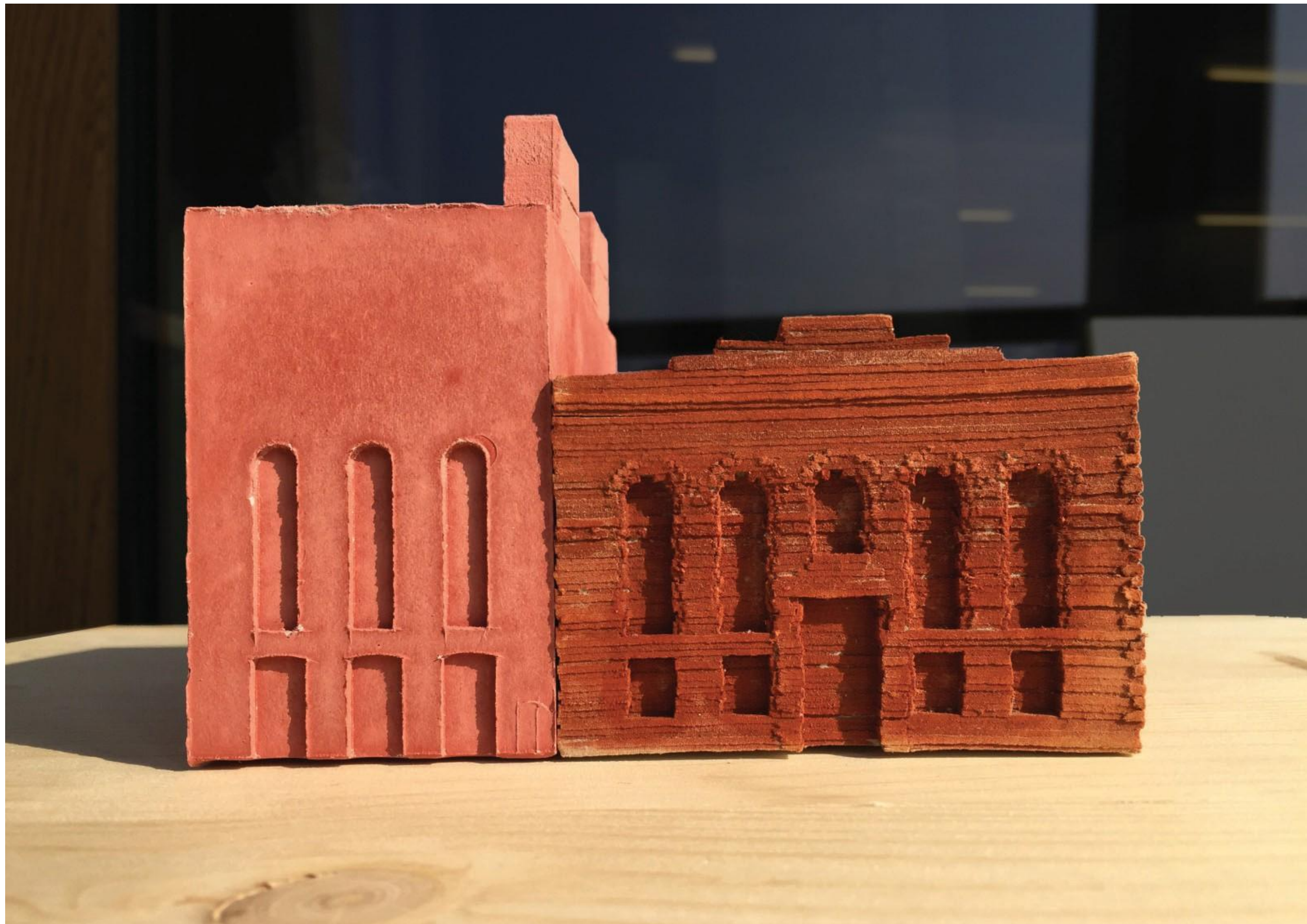

461 Powerhouse  
Arts







461 Powerhouse  
Arts



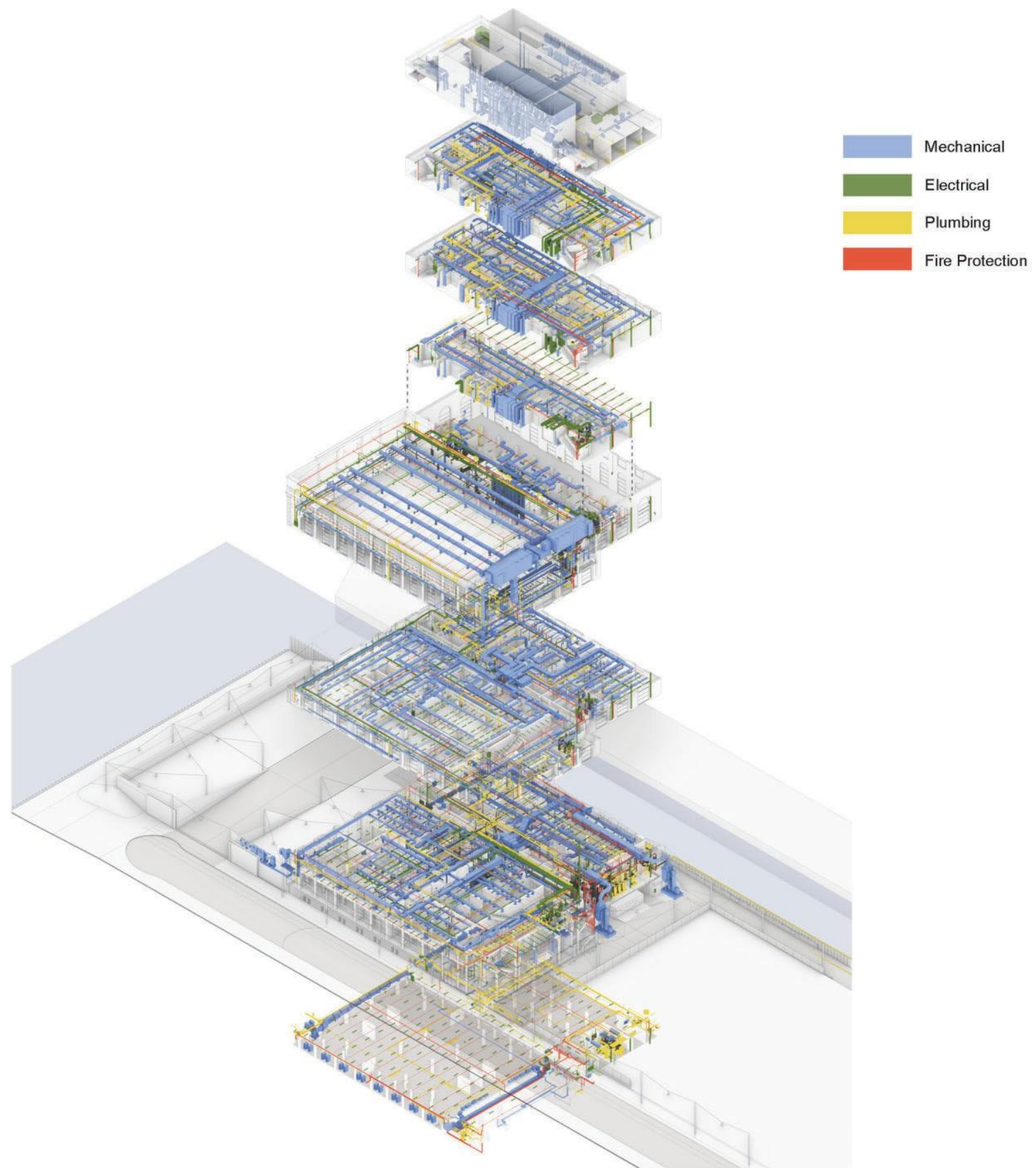

461 Powerhouse  
Arts

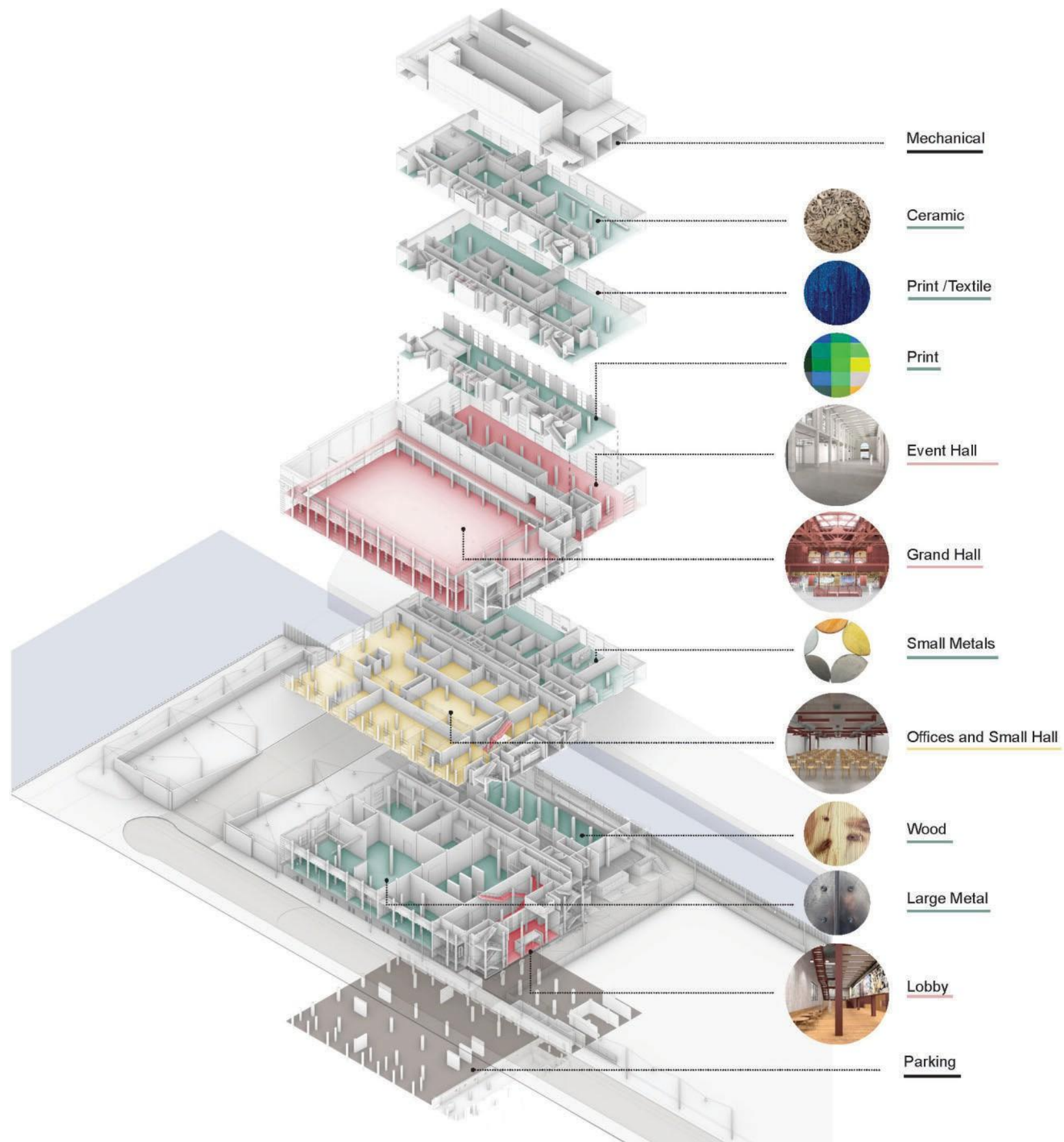

**A**

461 Powerhouse  
Arts















# **201 CaixaForum Madrid**

Madrid, Spain

Project: 2001-2003, Realization: 2003-2008





201 CaixaForum





201 CaixaForum



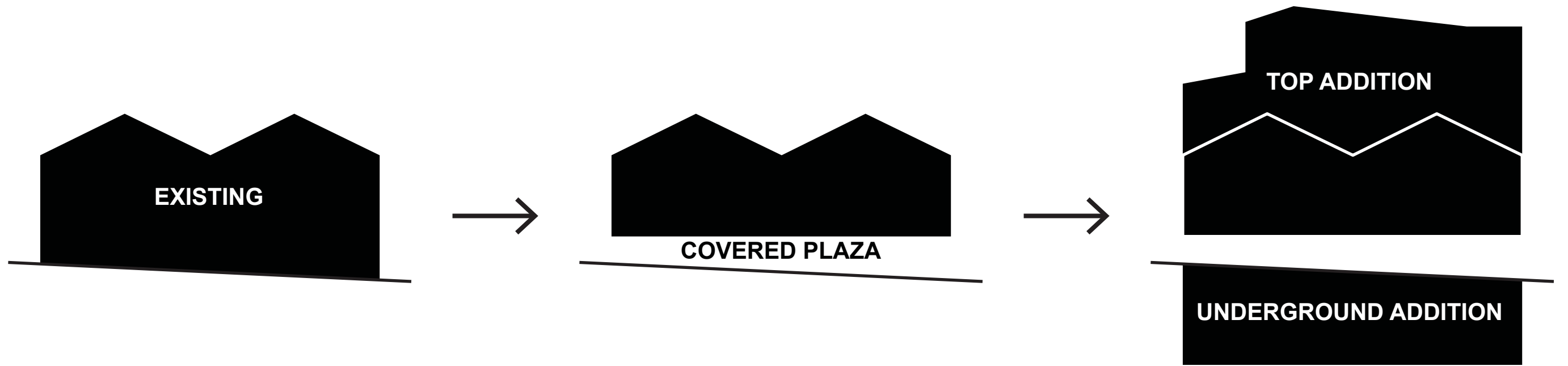





201 CaixaForum





























 CaixaForum



# **230 Elbphilharmonie Hamburg**

Hamburg, Germany

Concept: 2001-2003, Project: 2004-2014, Realization: 2006-2016





230 Elbphilharmonie Hamburg





230 Elbphilharmonie Hamburg



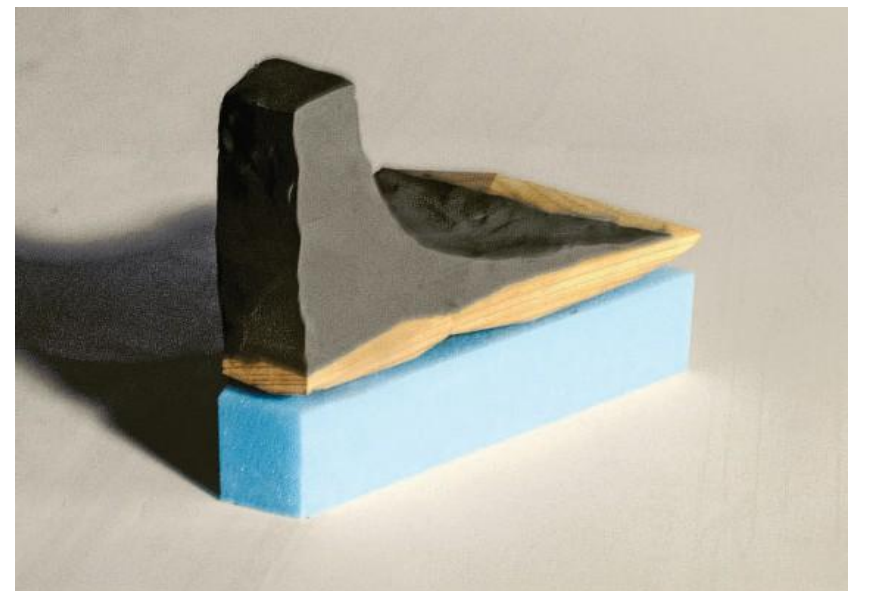
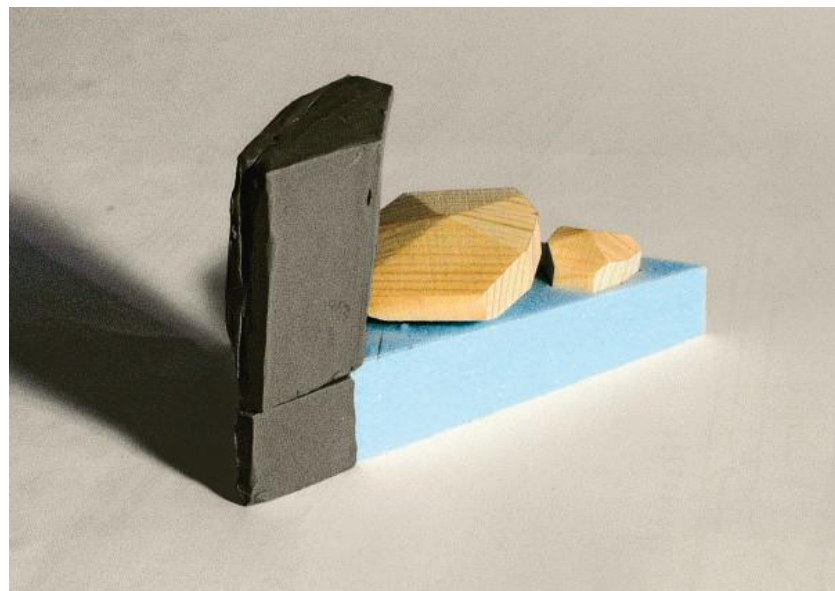



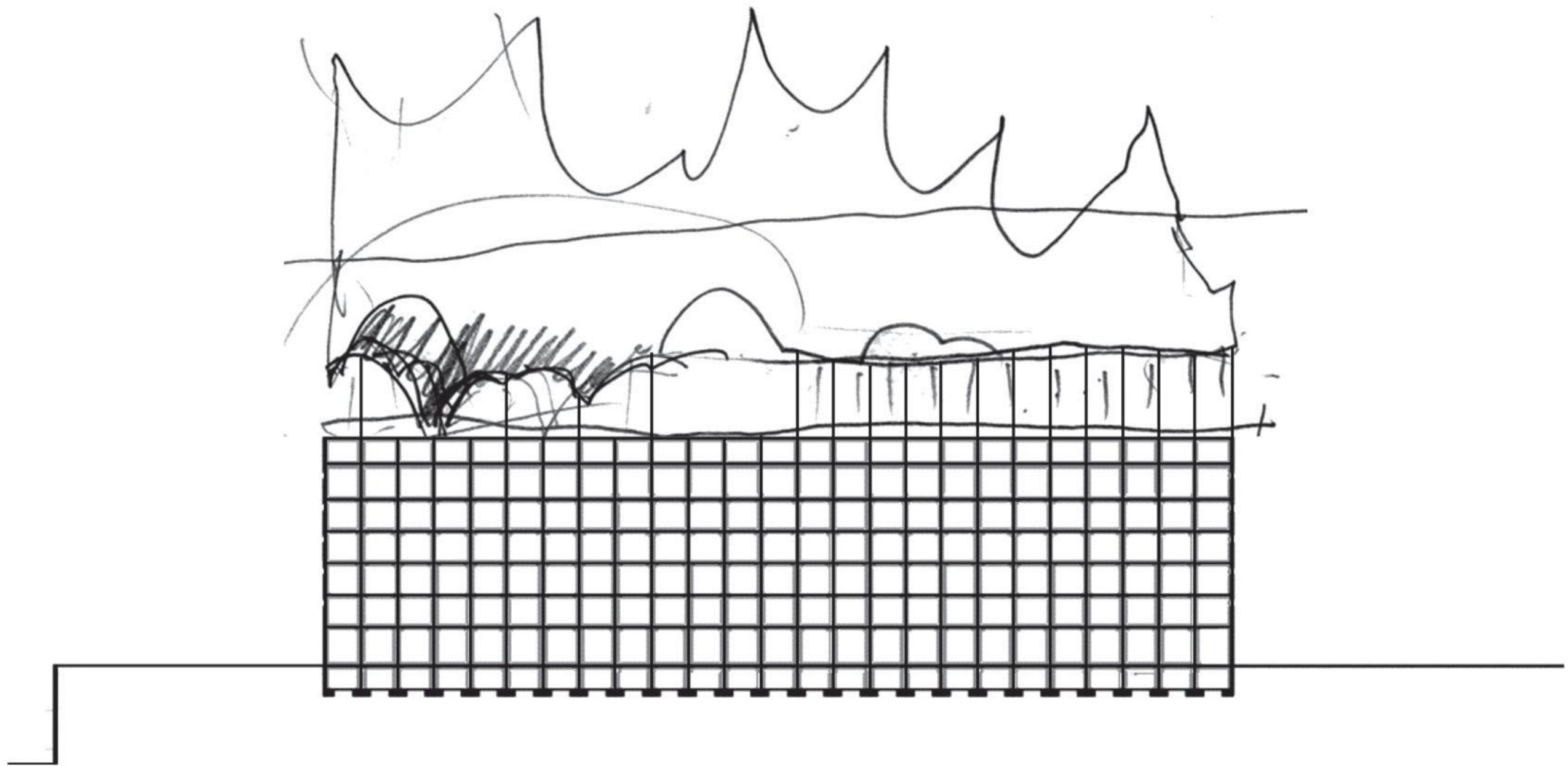

230 Elbphilharmonie Hamburg















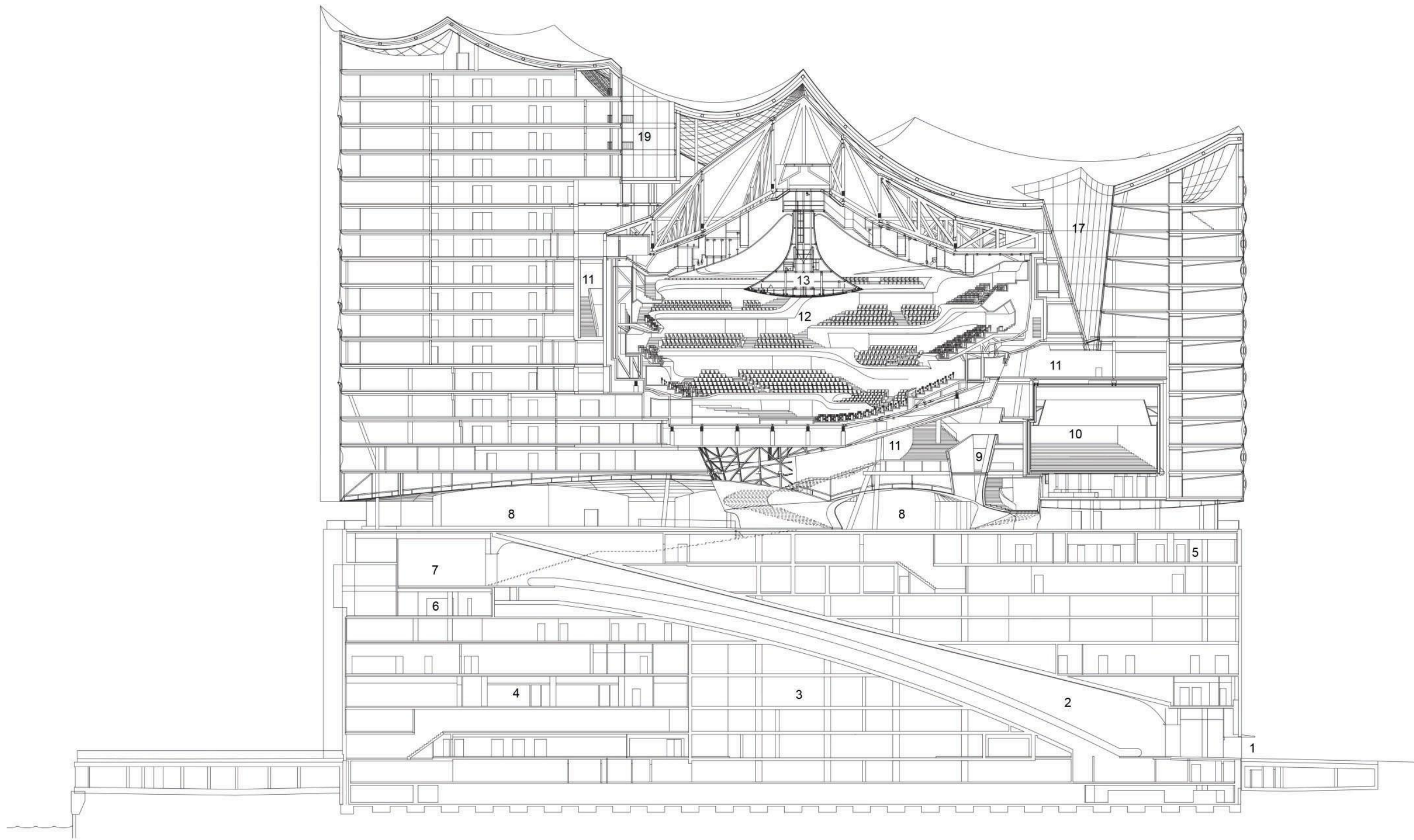

230 Elbphilharmonie Hamburg































**324 New Headquarters for  
BBVA**

Madrid, Spain

Competition: 2007, Project: 2007-2010, Realization: 2009-2015





324 New Headquarters for  
BBVA





324 New Headquarters for  
BBVA



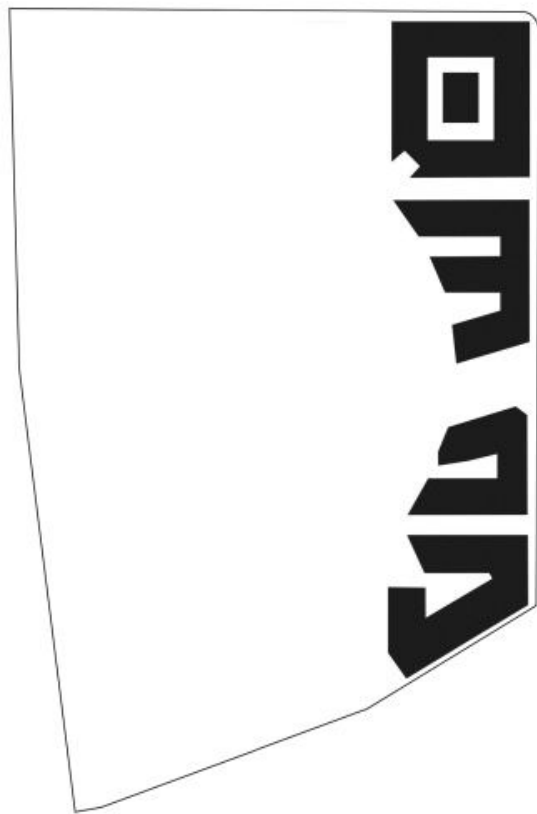

**EXISTING**

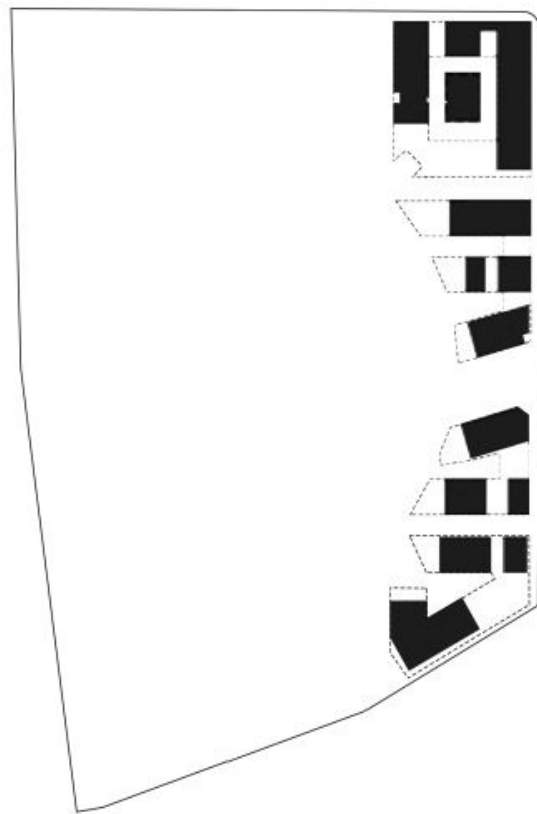

**DEMOLITION**

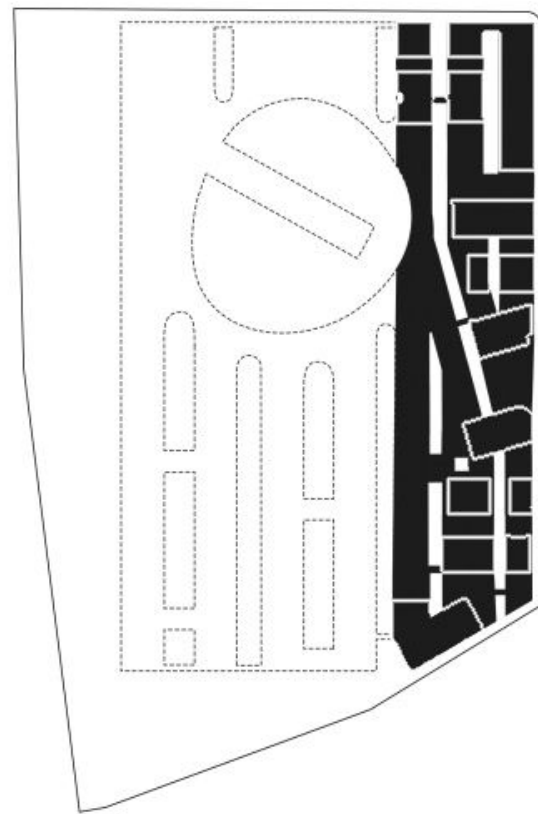

**FILL-IN**

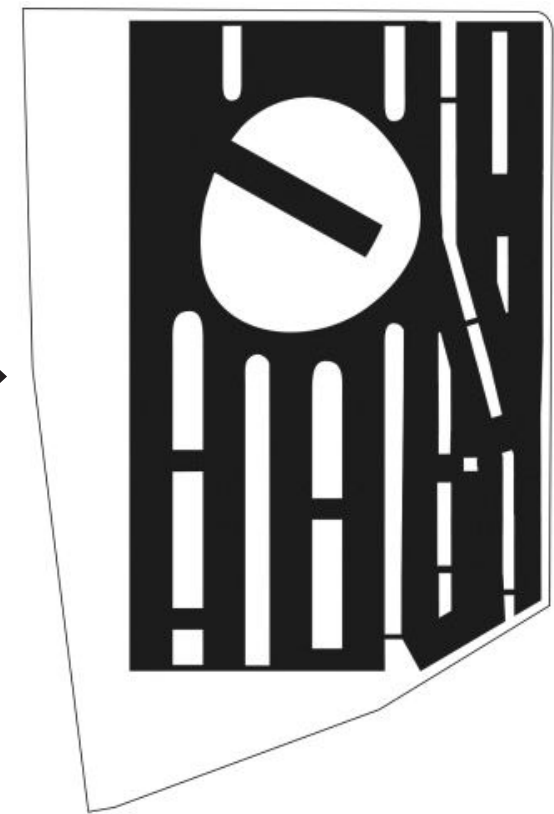

**EXTENSION**

324 New Headquarters for  
BBVA



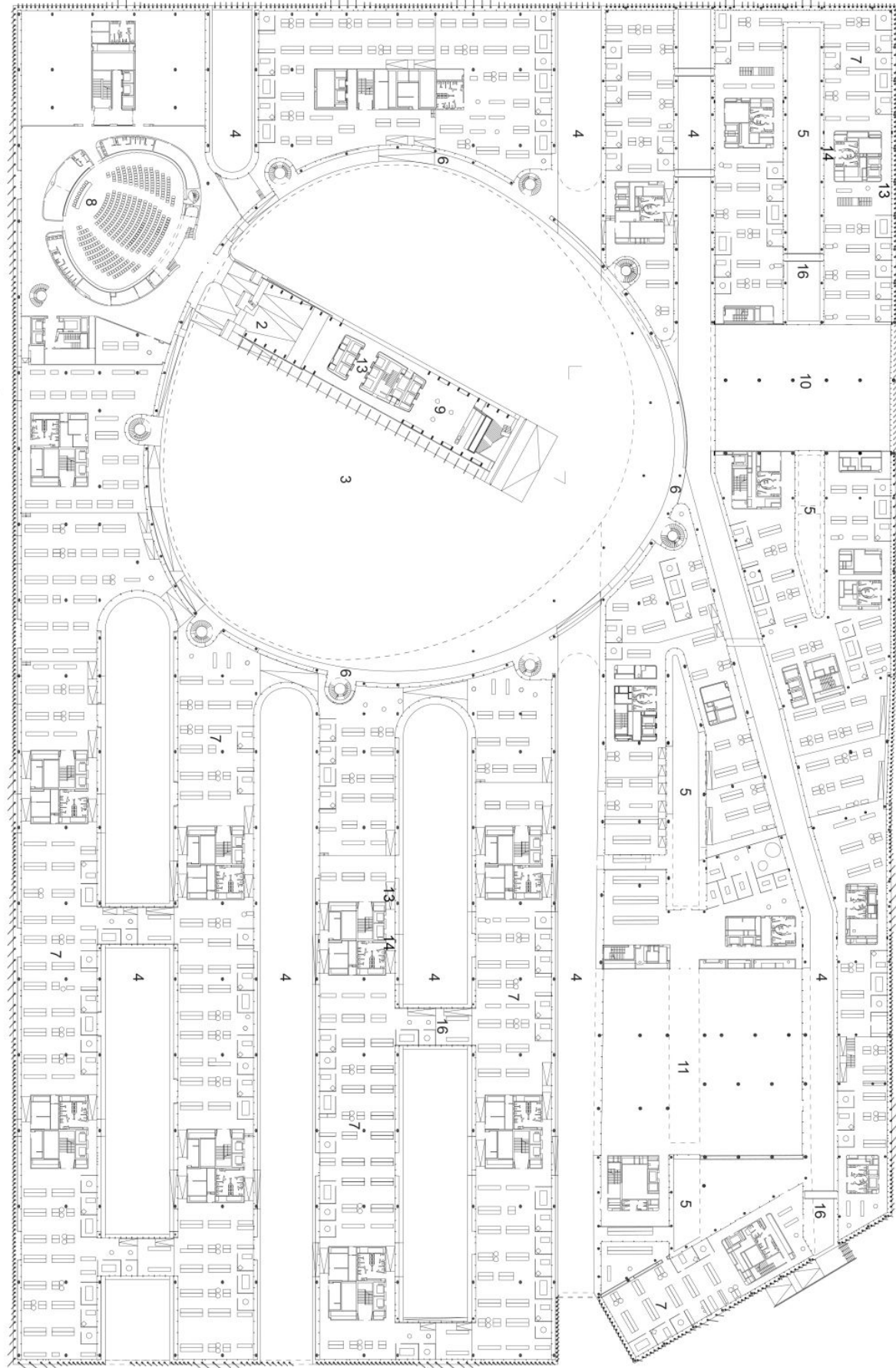

324 New Headquarters for  
BBVA





324 New Headquarters for  
BBVA































# **419 Helvetia Campus Basel**

Basel, Switzerland

Competition: 2013, Project: 2014-2019, Realization 1: 2020-2024, Realization 2: 2024-



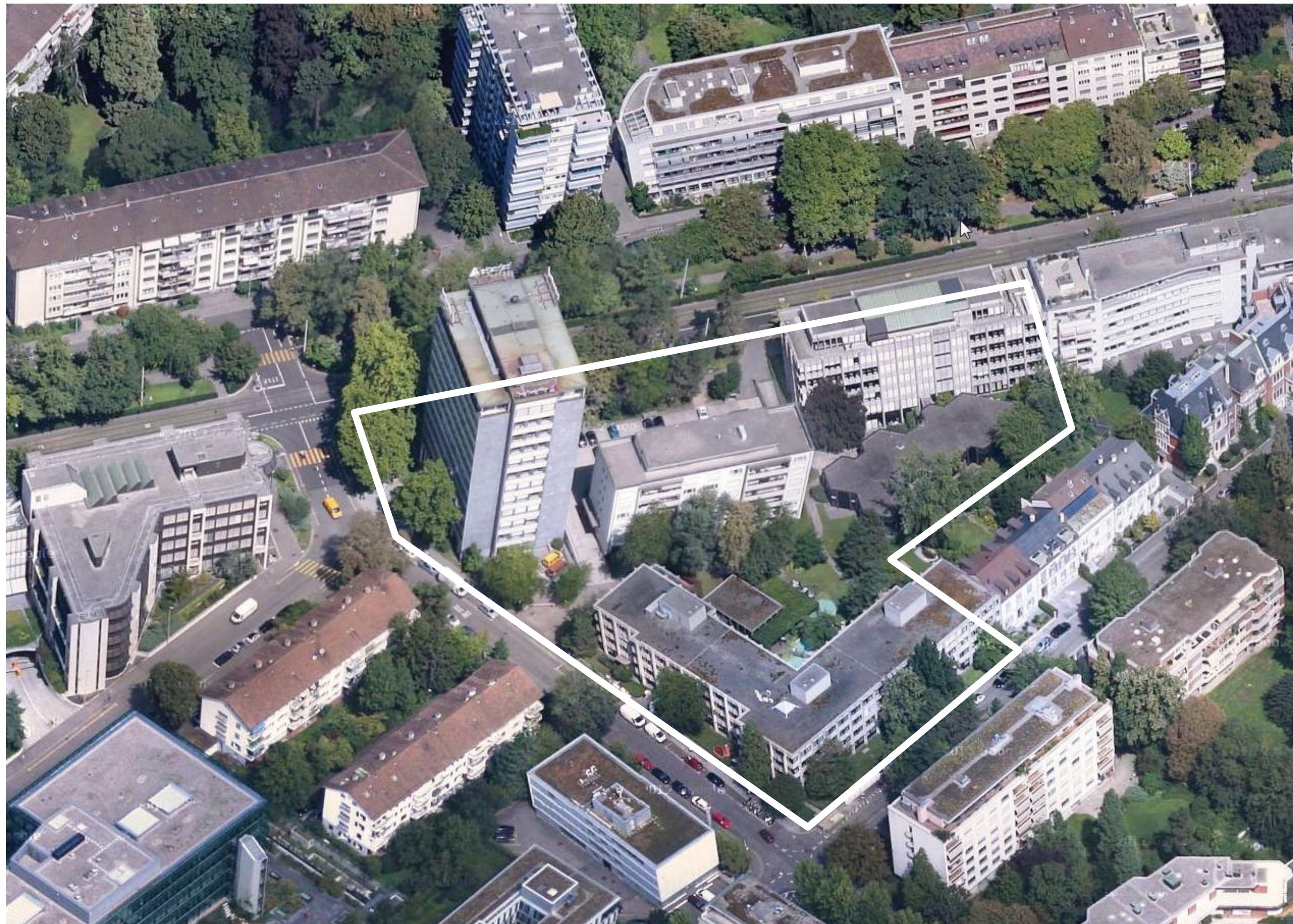

419 Helvetia Campus Basel





419 Helvetia Campus Basel



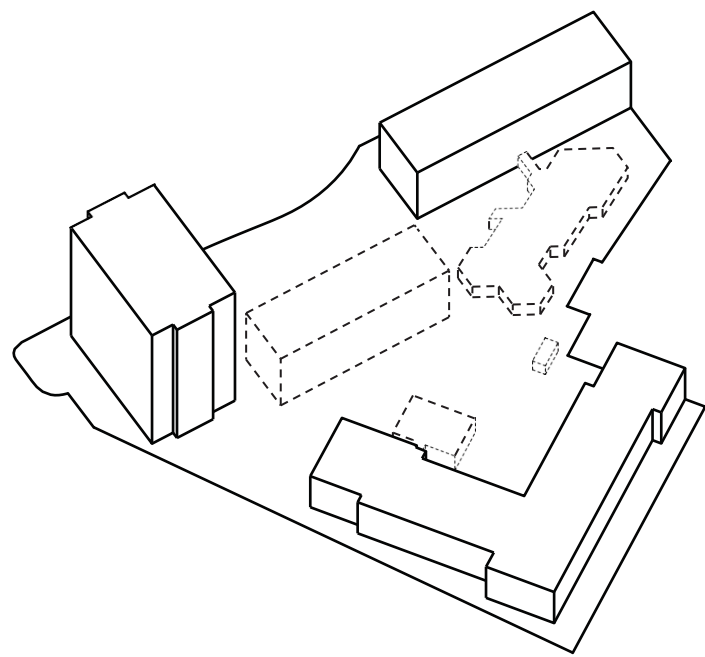

DEMOLISHING >  
PARK

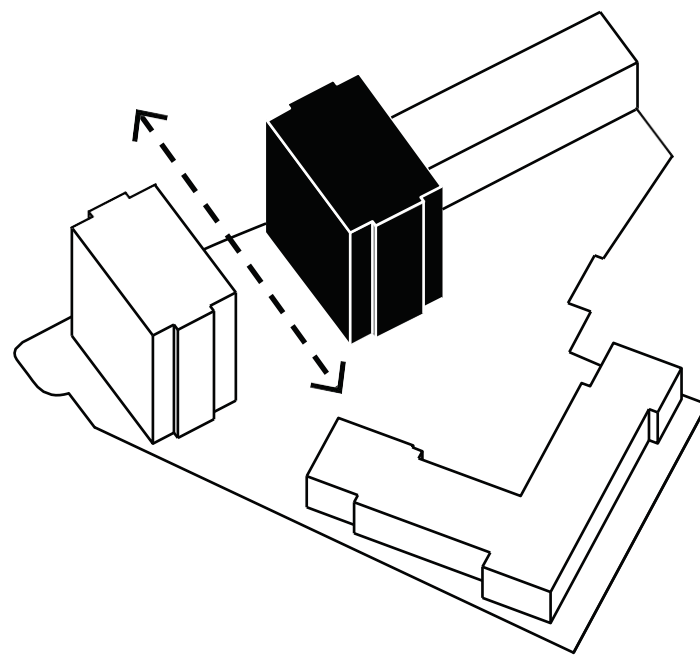

DUBLICATING > CENTER

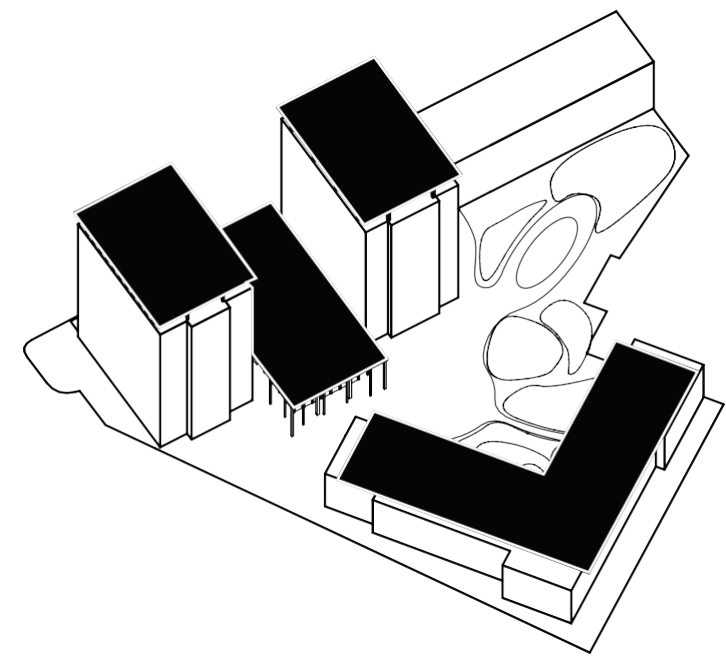

FLYING ROOFS >  
IDENTITY

# 419 Helvetia Campus Basel















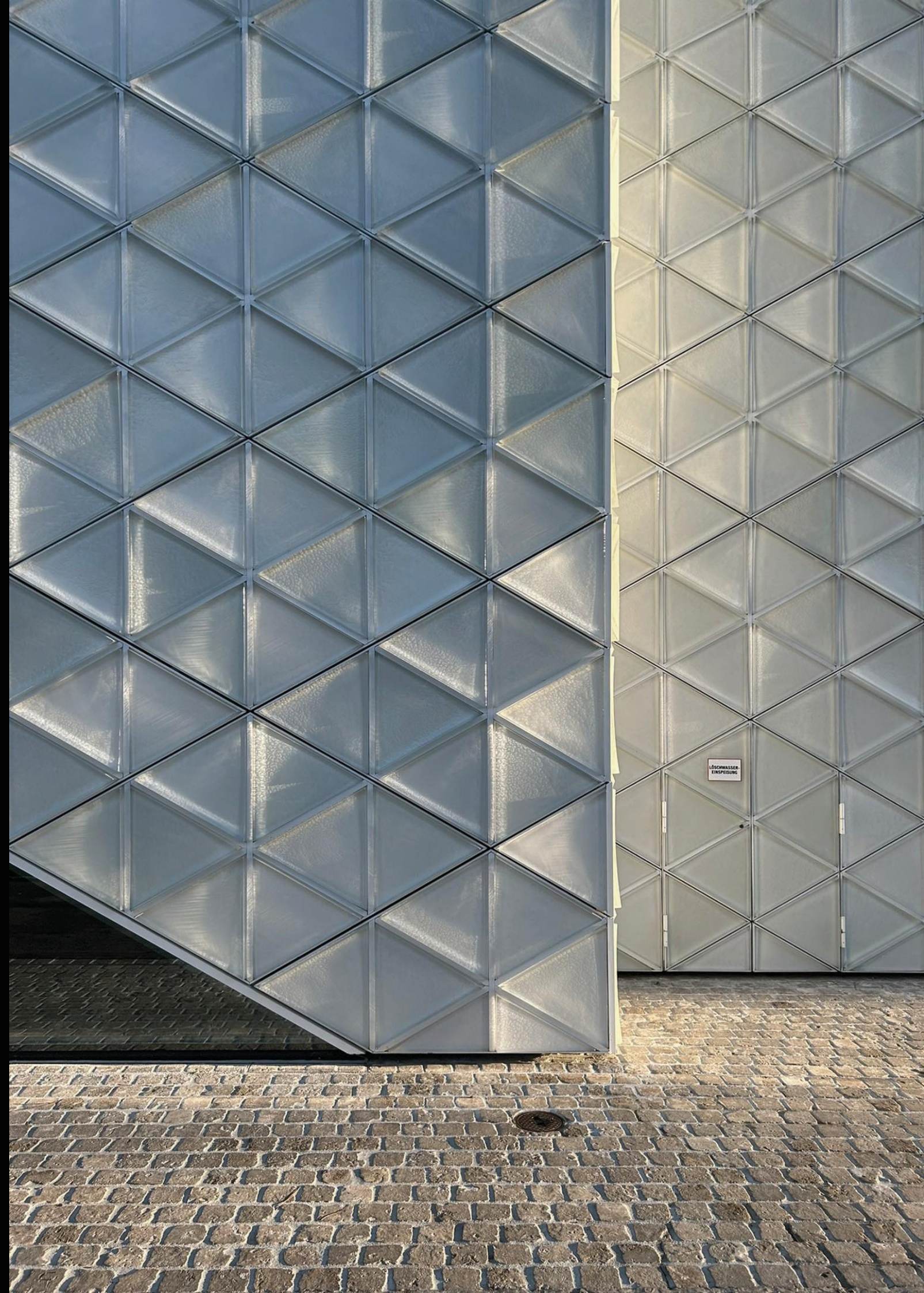

LÖSCHWASSER-  
EINFÜHRUNG

































James Turrell, Twilight Epiphany, Rice University, Houston, Texas, 2012























**517 Uniclo**

**Tokyo**

Tokyo Japan

Project: 2019-2020, Realization: 2020





517 Uniclo  
Tokyo





517 Uniclo  
Tokyo



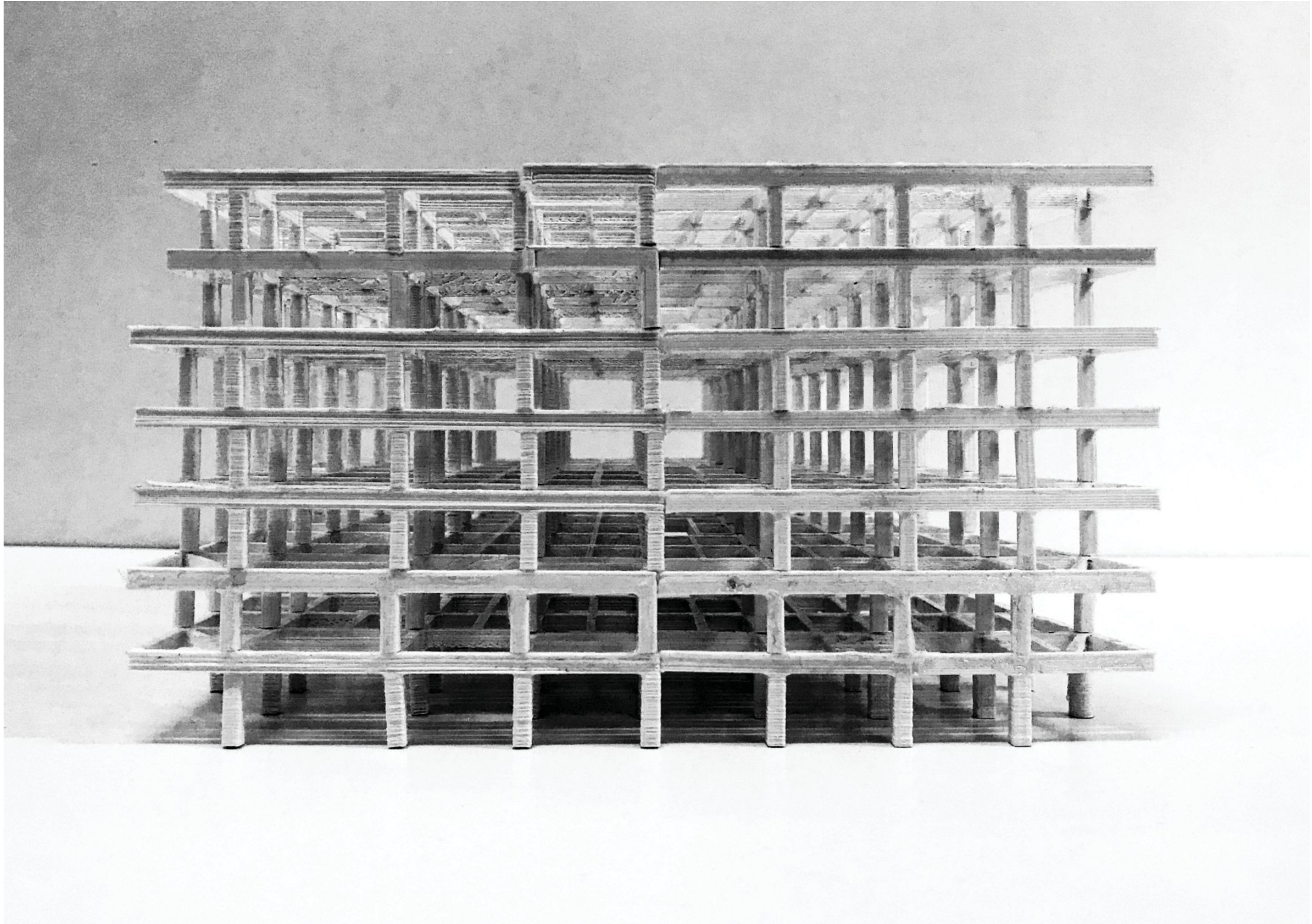

517 Uniclo  
Tokyo



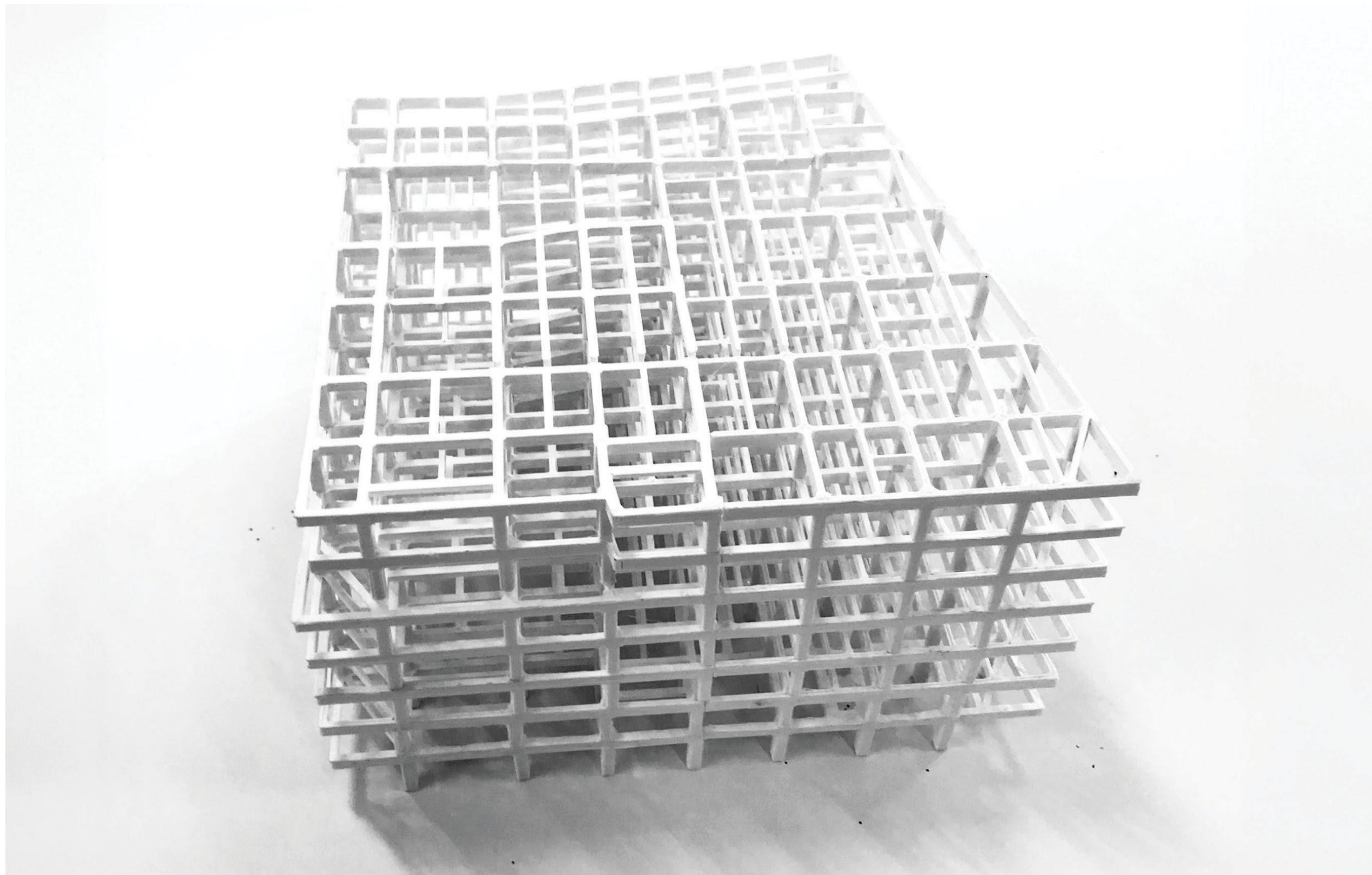

517 Uniclo  
Tokyo





















UNIQLO  
ユニクロ

UNIQLO  
ユニクロ

UNIQLO  
ユニクロ

UNIQLO  
ユニクロ

UNIQLO  
ユニクロ

UNIQLO  
ユニクロ

UNIQLO  
ユニクロ

REI-POW-CO.



# 492 Mandarin Oriental Lago Como

Blevio, Como, italy

Project: 2021-, Realization Phase 1: 2023





492 Mandarin Oriental Lago Como









492 Mandarin Oriental Lago Como









492 Mandarin Oriental Lago Como













492 Mandarin Oriental Lago Como













492 Mandarin Oriental Lago Como















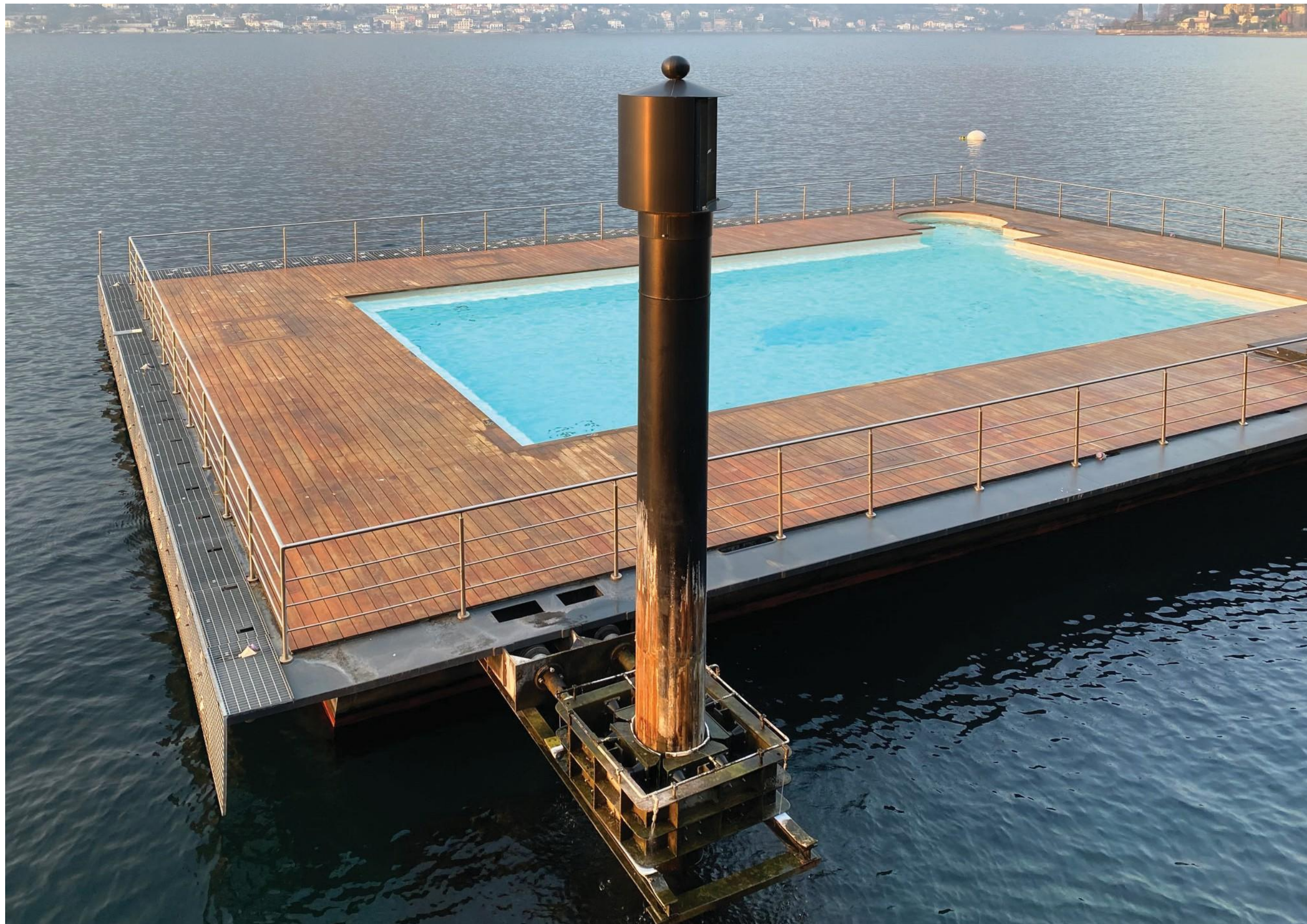

492 Mandarin Oriental Lago Como











**Revealing the Qualities of a Site & Activating its Potential**



© October 2024, Herzog & de Meuron.

Dieses Dokument und die darin enthaltenen Ideen sind das Eigentum von Herzog & de Meuron.  
Seine Verwendung ist zwischen dem Kunden und Herzog & de Meuron vertraglich geregelt.  
Für jede anderweitige Verwendung ist eine vorherige schriftliche Genehmigung von Herzog & de Meuron erforderlich.

Sofern nicht anders vermerkt, ist sämtliches, in diesem Dokument verwendete Material das Eigentum von Herzog & de Meuron.  
Es wurden alle Bemühungen unternommen, sämtliche Quellen- und Urheberrechtsinhaber von urheberrechtlich geschütztem Material,  
das nicht Eigentum von Herzog & de Meuron ist, zu ermitteln und zu bezeichnen.

Wir entschuldigen uns, sollte es hierbei zu Fehlern oder Auslassungen gekommen sein.  
Wir werden uns bemühen, diese Nachweise bei späterer Verwendung zu korrigieren.